

INSTRUCTIONS

MODEL AVB1-5-C-833

0 TO 100 VOLT, 1 MHz

MONOCYCLE GENERATOR

WITH 833 MHz CENTER FREQUENCY

SERIAL NUMBER: _____

WARRANTY

Avtech Electrosystems Ltd. warrants products of its manufacture to be free from defects in material and workmanship under conditions of normal use. If, within one year after delivery to the original owner, and after prepaid return by the original owner, this Avtech product is found to be defective, Avtech shall at its option repair or replace said defective item. This warranty does not apply to units which have been disassembled, modified or subjected to conditions exceeding the applicable specifications or ratings. This warranty is the extent of the obligation assumed by Avtech with respect to this product and no other warranty or guarantee is either expressed or implied.

TECHNICAL SUPPORT

Phone: 613-226-5772 or 1-800-265-6681

Fax: 613-226-2802 or 1-800-561-1970

E-mail: info@avtechpulse.com

World Wide Web: <http://www.avtechpulse.com>

TABLE OF CONTENTS

WARRANTY	2
TECHNICAL SUPPORT	2
TABLE OF CONTENTS	3
INTRODUCTION	5
AVAILABLE OPTIONS	5
SPECIFICATIONS	6
EC DECLARATION OF CONFORMITY	7
INSTALLATION	8
VISUAL CHECK	8
LINE VOLTAGE SELECTION	8
CONNECTION TO THE POWER SUPPLY	9
POWER RATINGS	10
ENVIRONMENTAL CONDITIONS	10
FUSES	11
AC FUSE REPLACEMENT	11
DC FUSE REPLACEMENT	12
FUSE RATINGS	12
FRONT PANEL CONTROLS	13
REAR PANEL CONTROLS	15
GENERAL INFORMATION	17
BASIC TEST ARRANGEMENT	17
FINE TUNING	17
MINIMIZING WAVEFORM DISTORTIONS	18
USE 50W TRANSMISSION LINES AND LOADS	18
USE LOW-INDUCTANCE LOADS	18
PREVENTING DAMAGE	18
MECHANICAL INFORMATION	19
TOP COVER REMOVAL	19
ELECTROMAGNETIC INTERFERENCE	19
MAINTENANCE	19

REGULAR MAINTENANCE	19
CLEANING	19
<i>PERFORMANCE CHECK SHEET</i>	<i>20</i>

Manual Reference: T:\instructword\AVB\AVB1-5-C-833,edition1.doc, created March 10, 2003

INTRODUCTION

The AVB1-5-C-833 monocyte generator produces peak-to-peak outputs of up to 100 Volts, at pulse repetition frequencies of up to 1 MHz. The center frequency of the monocyte waveform is 833 MHz. A one-turn front-panel control allows limited tuning ($\pm 20\%$) of the center frequency.

The output is designed to drive 50Ω loads. (A 50Ω load is required for proper operation.) The output is AC-coupled.

This instrument is intended for use in research and development laboratories.

AVAILABLE OPTIONS

"-OS" Option: allows an externally generated DC offset to be added to the output.

"-R5" Option: allows the instrument to be rack-mounted.

SPECIFICATIONS

Model:	AVB1-5-C ¹
Frequency: (MHz)	250 - 833 fixed-tuned ² , $\pm 20\%$
Amplitude: (V_{pp} , 50 Ohms)	0 to 100
PRF _{max} (MHz):	1.0
Spurious signals: (WRT peak)	26 dB
Propagation delay:	≤ 50 ns (Ext trig in to pulse out)
Jitter:	± 15 ps (Ext trig in to pulse out)
DC offset option ³ :	Apply required DC offset (± 50 Volts, 250 mA max) to back-panel solder terminals
Trigger required:	Ext trig mode: +5 Volts, 50 to 500 ns (TTL)
Sync delay:	Sync out to pulse out: Variable 0 to 200 ns
Sync output:	+ 3 Volts, 200 ns, will drive 50 Ohm loads
Connectors:	Out: SMA, Trig: BNC, Sync: BNC
Power requirements:	120/240 Volts (switchable) 50 - 60 Hz
Dimensions:	100 x 215 x 375 mm (3.9" x 8.5" x 14.8")

1) -C suffix indicates stand-alone lab instrument with internal clock and line powering.

2) The required center frequency in the range of 250 MHz to 833 MHz must be specified at the time of ordering. A one-turn front-panel control allows tuning ($\pm 20\%$) around the specified center frequency.

3) For DC offset option suffix model number with -OS. Avtech Model AVX-T bias tee can also be used to obtain DC offset.

EC DECLARATION OF CONFORMITY

We

Avtech Electrosystems Ltd.
P.O. Box 5120, LCD Merivale
Ottawa, Ontario
Canada K2C 3H4

declare that this pulse generator meets the intent of Directive 89/336/EEC for Electromagnetic Compatibility. Compliance pertains to the following specifications as listed in the official Journal of the European Communities:

EN 50081-1 Emission

EN 50082-1 Immunity

and that this pulse generator meets the intent of the Low Voltage Directive 72/23/EEC as amended by 93/68/EEC. Compliance pertains to the following specifications as listed in the official Journal of the European Communities:

EN 61010-1:2001 Safety requirements for electrical equipment for measurement, control, and laboratory use



INSTALLATION

VISUAL CHECK

After unpacking the instrument, examine to ensure that it has not been damaged in shipment. Visually inspect all connectors, knobs, and handles. Confirm that a power cord is with the instrument. If the instrument has been damaged, file a claim immediately with the company that transported the instrument.

LINE VOLTAGE SELECTION

Examine the rear of the instrument. There will be a power-entry module consisting of a male power receptacle, the main power switch, and a fuse holder / voltage selector. Confirm that the voltage selector is in the correct orientation. For AC line voltages of $115\text{V} \pm 10\%$, 50 - 60 Hz, the power selector card should be installed so that the "115" marking is visible from the rear of the instrument. For AC line voltages of $230\text{V} \pm 10\%$, 50 - 60 Hz, the power selector card should be installed so that the "230" marking is visible from the rear of the instrument. The two possible settings are shown below:

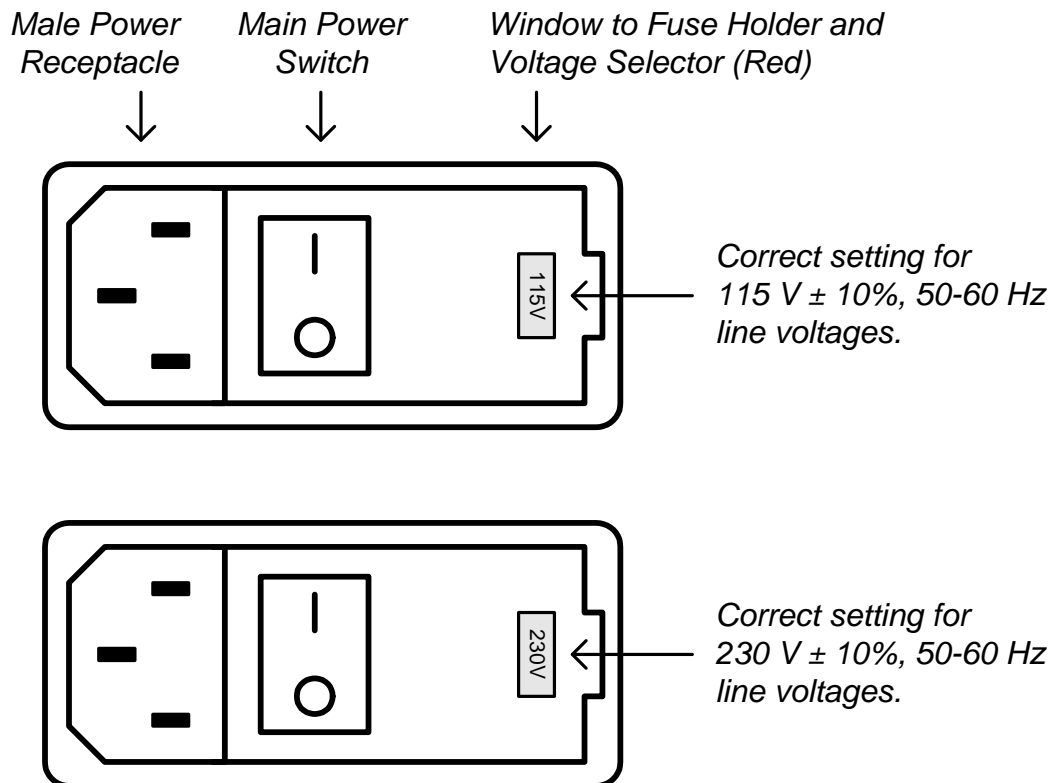

If the voltage selector is not set for to proper voltage, use a small flat-head screwdriver to pry open the voltage selector panel, as shown below:

Fuse Holder and Voltage Selector Panel.

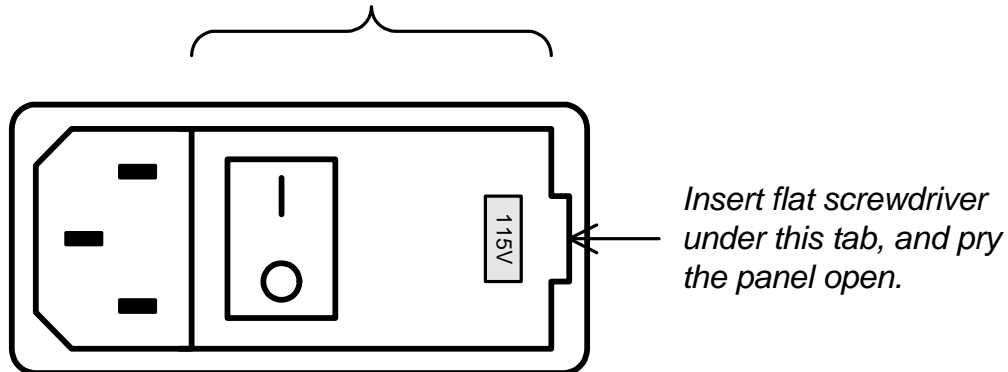

*Fuse Holder and Voltage Selector.
After opening the panel, the red plastic
fuse holder and voltage selector will be
visible.*

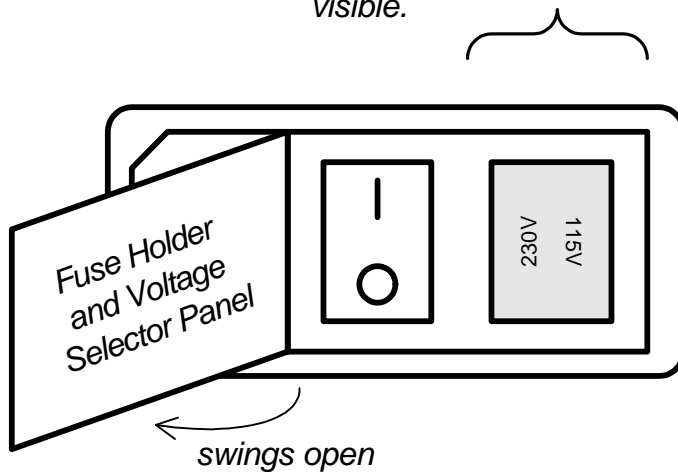

Once the panel is open, the red fuse holder / voltage selector should be visible. To change the voltage setting, pull out the red fuse holder / voltage selector and rotate it so that the proper voltage marking will shown through the panel window. Re-install the red fuse holder / voltage selector, and close the panel.

CONNECTION TO THE POWER SUPPLY

An IEC-320 three-pronged recessed male socket is provided on the back panel for AC power connection to the instrument. One end of the detachable power cord that is supplied with the instrument plugs into this socket. The other end of the detachable power cord plugs into the local mains supply. Use only the cable supplied with the instrument. The mains supply must be earthed, and the cable used to connect the

instrument to the mains supply must provide an earth connection. (The supplied cable does this.)

POWER RATINGS

This instrument is intended to operate from 115 / 230 V \pm 10%, 50-60 Hz. The maximum power consumption is 28 W. This instrument is an "Installation Category II" instrument, intended for operation from a normal single-phase supply.

ENVIRONMENTAL CONDITIONS

This instrument is intended for use under the following conditions:

- a) indoor use;
- b) altitude up to 2 000 m;
- c) temperature 5 °C to 40 °C;
- d) maximum relative humidity 80 % for temperatures up to 31 °C decreasing linearly to 50 % relative humidity at 40 °C;
- e) Mains supply voltage fluctuations up to \pm 10 % of the nominal voltage;
- f) no pollution or only dry, non-conductive pollution.

FUSES

This instrument contains four fuses. All are accessible from the rear-panel. Two protect the AC prime power input, and two protect the internal DC power supplies. The locations of the fuses on the rear panel are shown in the figure below:

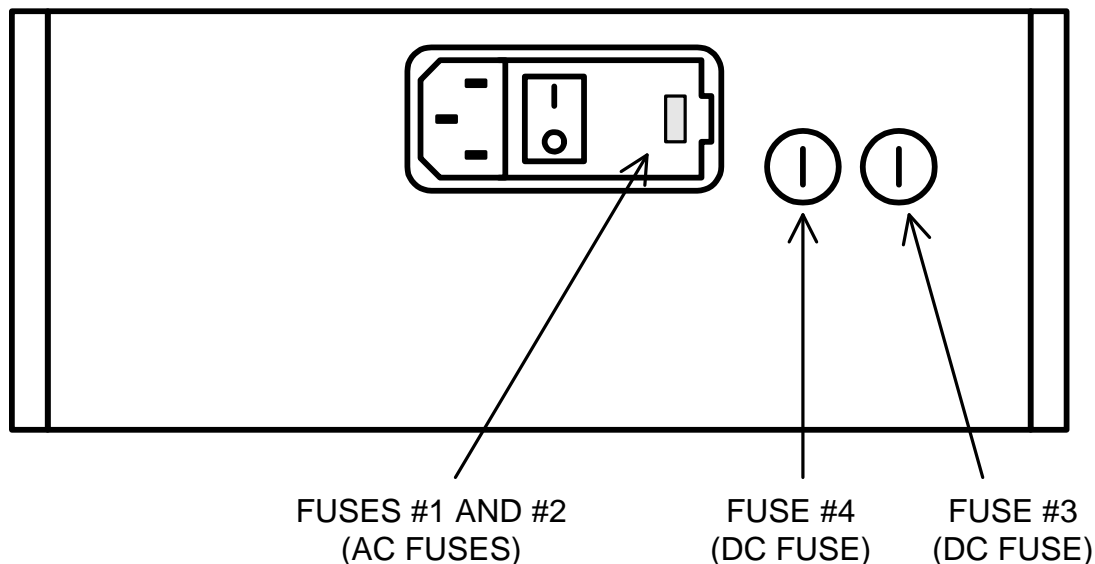

AC FUSE REPLACEMENT

The red fuse holder / voltage selector described in the previous section contains two fuses. One protects the AC “Line” input, and one protects the AC “Neutral” input. To replace the AC fuses, pull out the red fuse holder / voltage selector (as described in the previous section). The location of the two identical 5 mm x 20 mm fuses is shown below:

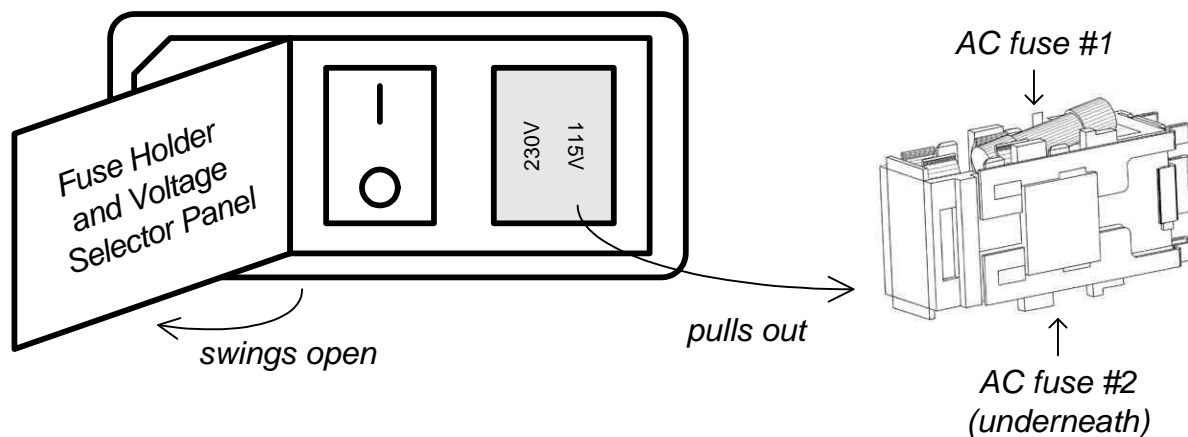

DC FUSE REPLACEMENT

The DC fuses may be replaced by inserting the tip of a flat-head screwdriver into the fuseholder slot, and rotating the slot counter-clockwise. The fuse and its carrier will then pop out.

FUSE RATINGS

The following table lists the required fuses:

Fuse	Mains Voltage	Rating	Case Size	Manufacturer's Part Number (Wickmann)	Distributor's Part Number (Digi-Key)
#1 (AC)	115 V	0.25A, 250V, Time-Delay	5 x 20 mm	1950250000	WK5035-ND
	230 V	0.125A, 250V, Time-Delay	5 x 20 mm	1950125000	WK5028-ND
#2 (AC)	115 V	0.25A, 250V, Time-Delay	5 x 20 mm	1950250000	WK5035-ND
	230 V	0.125A, 250V, Time-Delay	5 x 20 mm	1950125000	WK5028-ND
#3 (DC)	115/230V	0.8A, 250V, Time-Delay	5 x 20 mm	1950800000	WK5046-ND
#4 (DC)	115/230V	Not Used*	5 x 20 mm	Not Used*	Not Used*

* A spare fuse, identical to fuse #3, is installed in this position. It is not electrically active.

The fuse manufacturer is Wickmann (<http://www.wickmann.com/>).

Replacement fuses may be easily obtained from Digi-Key (<http://www.digikey.com/>) and other distributors.

FRONT PANEL CONTROLS

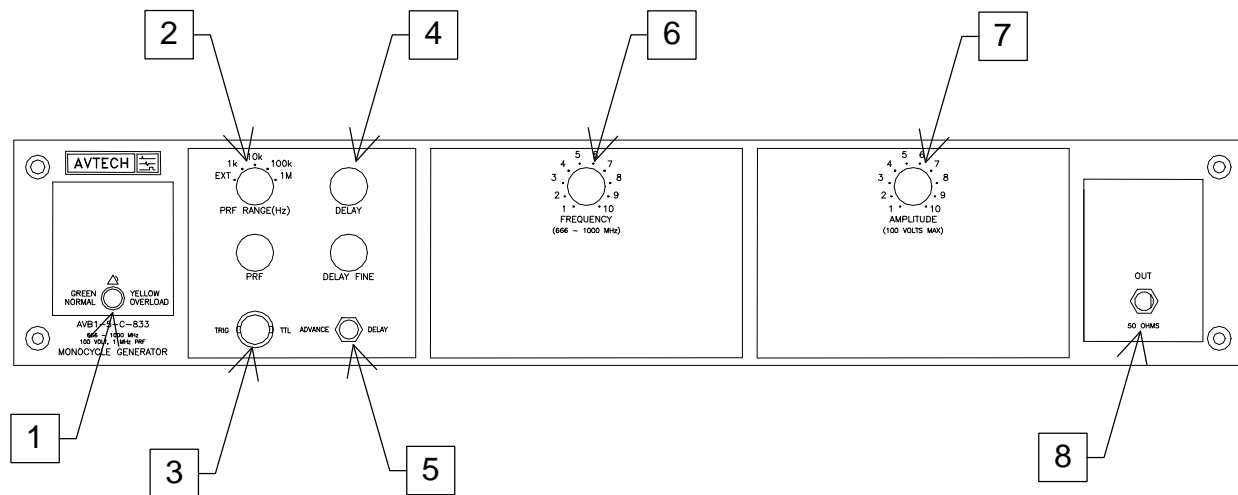

1. OVERLOAD Indicator. When the instrument is powered, this indicator is normally green, indicating normal operation. If this indicator is yellow, an internal automatic overload protection circuit has been tripped. If the unit is overloaded (by operating at an exceedingly high duty cycle or by operating into a very low impedance), the protective circuit will disable the output of the instrument and turn the indicator light yellow. The light will stay yellow (i.e. output disabled) for about 5 seconds after which the instrument will attempt to re-enable the output (i.e. light green) for about 1 second. If the overload condition persists, the output will be disabled again (i.e. light yellow) for another 5 seconds. If the overload condition has been removed, the instrument will resume normal operation.

This overload indicator may flash yellow briefly at start-up. This is not a cause for concern.

2. PRF Range Switch. This switch sets the pulse repetition frequency (PRF) range of the internal oscillator. The marked value of each position is the upper limit of the 10:1 range, approximately. The vernier dial directly below the switch varies the PRF within the set range.

If this switch is set to the "EXT" position, the instrument is triggered by a signal applied to the TRIG connector, rather than by the internal oscillator.

3. TRIG Connector. When the PRF Range Switch is set to "EXT", the instrument is triggered by a TTL pulse applied to this connector. The pulse must be at least 50 ns wide.

When the PRF Range Switch is set to one of the four internal oscillator ranges, this

connector is an output, which supplies a 2V, 200 ns wide pulse for each trigger event. This output may be used to trigger oscilloscopes or other equipment.

4. Delay Controls. When the PRF Range Switch is set to one of the four internal oscillator ranges, the main output is advanced or delayed relative to the TRIG output pulse (item 3). The delay is variable up to 200 ns, approximately, using the DELAY and DELAY FINE dials.
5. Advance/Delay Switch. When the PRF Range Switch is set to one of the four internal oscillator ranges, this switch determines whether the TRIG output precedes the main output (ADVANCE mode), or whether the TRIG output occur after the main output (DELAY mode).
6. Frequency Adjust. This dial varies the center frequency of the output monocycle waveform over a $\pm 20\%$ range.
7. Amplitude Control. This dial controls the pulse amplitude.
8. OUT Connector. This is the main output. (This output *requires* a 50Ω load to function properly).

REAR PANEL CONTROLS

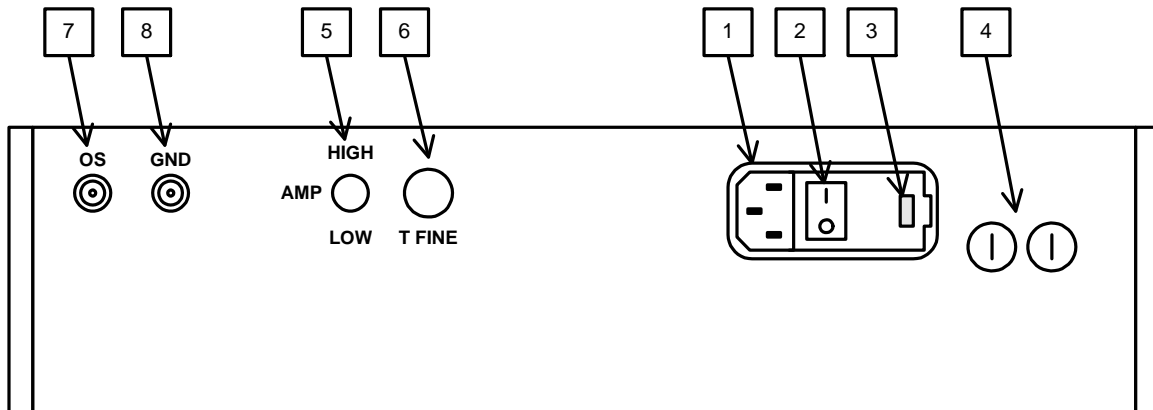

1. AC POWER INPUT. An IEC-320 three-pronged recessed male socket is provided on the back panel for AC power connection to the instrument. One end of the detachable power cord that is supplied with the instrument plugs into this socket.
2. POWER SWITCH. This is the main power switch. The instrument should be positioned so that the switch is accessible.
3. FUSE HOLDER / VOLTAGE SELECTOR. This red plastic module must be installed so that the marked voltage equals the AC line voltage. This module also contains two fuses that protect the AC inputs. Please see the “LINE VOLTAGE SELECTION” and “FUSES” sections of this manual for more information.
4. DC FUSES. These two fuses protect the internal DC power supplies. Please see the “FUSES” sections of this manual for more information.
5. AMP Switch. When this switch is set to the “HIGH” position, the output amplitude is slightly higher (approximately 10%) than when set to the “LOW” position, but the spurious transients following the main output waveform may also be higher (particularly at reduced amplitudes).
6. T FINE. This one-turn control is used to fine-tune the time separation between the positive and negative output voltage swings that form the output monocycle waveform. For pulse repetition frequencies of 0 to 100 kHz, this control may be left at one fixed setting, and the front-panel “Center Frequency” control may be used to adjust the waveform. However, when operating with pulse repetition frequencies between 100 kHz and 1 MHz, it may be necessary to adjust the control in conjunction with the “Center Frequency” control in order to obtain the full tuning range.

7. OS INPUT CONNECTOR. For units with the -OS option only. A DC offset in the range of $\pm 50\text{V}$ (250 mA max) may be applied to this solder terminal. The DC offset will appear on the output. When this feature is not used, the OS input should be connected to ground (using the adjacent GND connector). This is especially important when driving loads containing a diode.
8. GND CONNECTOR. For units with the -OS option only. This solder terminal is connected to ground. It may be used to ground the OS input connector.

GENERAL INFORMATION

BASIC TEST ARRANGEMENT

The AVB1-5-C-833 should be tested with a sampling oscilloscope with a bandwidth of at least 10 GHz to properly observe the high-speed waveform. A typical test arrangement is shown below:

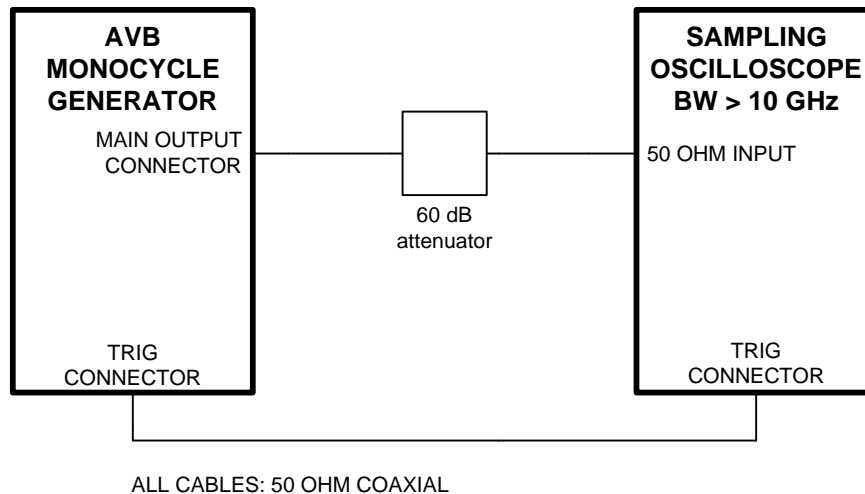

The bandwidth capability of components and instruments used to display the pulse generator output signal (attenuators, cables, connectors, etc.) should exceed 10 GHz.

The attenuators are required to prevent damage to the sampling oscilloscope. A 60 dB attenuator with sufficient voltage rating should be used on the main output.

FINE TUNING

The amplitude is controlled primarily by the front-panel AMPLITUDE dial, but the rear-panel AMP HIGH / LOW switch also has an effect. When this switch is set to the "HIGH" position, the output amplitude is slightly higher (approximately 10%) than when set to the "LOW" position, but the spurious transients following the main output waveform may also be higher (particularly at reduced amplitudes).

The monocyte center frequency is controlled primarily by the front-panel FREQUENCY dial, but the rear-panel T FINE dial also has an effect. This one-turn control is used to fine-tune the time separation between the positive and negative output voltage swings that form the output monocyte waveform. For pulse repetition frequencies of 0 to 100 kHz, this control may be left at one fixed setting, and the front-panel "Center Frequency" control may be used to adjust the waveform. However, when operating with pulse repetition frequencies between 100 kHz and 1 MHz, it may be necessary to

adjust the control in conjunction with the “Center Frequency” control in order to obtain the full tuning range.

MINIMIZING WAVEFORM DISTORTIONS

USE 50Ω TRANSMISSION LINES AND LOADS

Connect the load to the pulse generator with 50Ω transmission lines (e.g. RG-58 or RG-174 cable).

This instrument requires a 50Ω load for proper operation. It will not properly drive a high-impedance load. The output stage will be damaged if it is operated into an open circuit (or any other high impedance). Failures due to improper output loading are not covered by the warranty.

USE LOW-INDUCTANCE LOADS

Lenz’s Law predicts that for an inductive voltage spike will be generated when the current through an inductance changes. Specifically, $V_{\text{SPIKE}} = L \times dI_{\text{LOAD}}/dt$, where L is the inductance, I_{LOAD} is the load current change, and t is time. For this reason, it is important to keep any parasitic in the load low. This means keeping wiring short, and using low inductance components. In particular, wire-wound resistors should be avoided.

PREVENTING DAMAGE

The AVB1-5-C-833 may fail if triggered at a PRF greater than 1 MHz.

This unit is designed to operate into a load impedance of 50 Ohms and the output stage may be damaged if it is operated into an open circuit (or any other high impedance). Failures due to improper output loading are not covered by the warranty.

The lifetime of the switching elements in the pulse generator module is proportional to the running time of the instrument. For this reason the prime power to the instrument should be turned off when the instrument is not in use.

MECHANICAL INFORMATION

TOP COVER REMOVAL

If necessary, the interior of the instrument may be accessed by removing the four Phillips screws on the top panel. With the four screws removed, the top cover may be slid back (and off).

Always disconnect the power cord before opening the instrument.

There are no user-adjustable internal circuits. For repairs other than fuse replacement, please contact Avtech (info@avtechpulse.com) to arrange for the instrument to be returned to the factory for repair.



Caution: High voltages are present inside the instrument during normal operation. Do not operate the instrument with the cover removed.

ELECTROMAGNETIC INTERFERENCE

To prevent electromagnetic interference with other equipment, all used outputs should be connected to shielded 50Ω loads using shielded 50Ω coaxial cables. Unused outputs should be terminated with shielded 50Ω BNC terminators or with shielded BNC dust caps, to prevent unintentional electromagnetic radiation. All cords and cables should be less than 3m in length.

MAINTENANCE

REGULAR MAINTENANCE

This instrument does not require any regular maintenance.

On occasion, one or more of the four rear-panel fuses may require replacement. All fuses can be accessed from the rear panel. See the “FUSES” section for details.

CLEANING

If desired, the interior of the instrument may be cleaned using compressed air to dislodge any accumulated dust. (See the “TOP COVER REMOVAL” section for instructions on accessing the interior.) No other cleaning is recommended.

PERFORMANCE CHECK SHEET